

Securing Continuous Electricity Supply in Industrial Plants

With growing business and production growth, many industries require increased supply of energy, and increasingly using electricity to offset former fuel-based energy. Oil & Gas rigs consume very high amounts of energy and rely on uninterrupted operation. With the fast growth of internet and cloud services, data centres are popping up like mushrooms and their energy consumption is growing rapidly. Many industries - such as semiconductor, chemical processes, steel and cement - are extremely sensitive to electricity disruptions which often lead to severe business impact and financial losses.

GridON is offering a cost-effective Fault Current Limiter (FCL) solution which enables secure supply of power to industrial grids. Following nearly four years of successful field operation in live distribution networks, GridON is announcing a new family of cost-effective fault current limiters for mid-to-high voltage applications. GridON's established technology has been further enhanced to offer an economical product with smaller footprint - for industrial customers and independent power producers. The development of the new product was co-funded by the Horizon 2020 programme of the European Union.



The FCL instantly suppresses excessive current and recovers to normal load promptly upon fault clearance - being always ready for consecutive short circuit events. The FCL increases network capacity and improves grid resilience and reliability, while significantly lowering capital expenditures and operating costs. The FCL is reliable and robust, and is easy to install and maintain.

Industrial plants are now able to apply this novel FCL for cost effective and reliable increase of supplied power in their electricity networks. GridON's FCL enables production growth, while reducing associated costs.

Industrial grid application example:

Following is an example of possible FCL implementation in an industrial network, which includes few motors and generators (e.g. an oil & gas rig or an industrial plant).

The prospective (or available) fault current in this example, without the FCL in the network, is 27kA. One option is placing a 19MVA FCL on the generator feeder, which will suppress through currents under 1kA and limit overall fault current in the network under 23kA. Another option is placing a 72MVA FCL in a bus-tie, which will suppress through currents under 8kA and limit overall fault current in the network under 19kA.

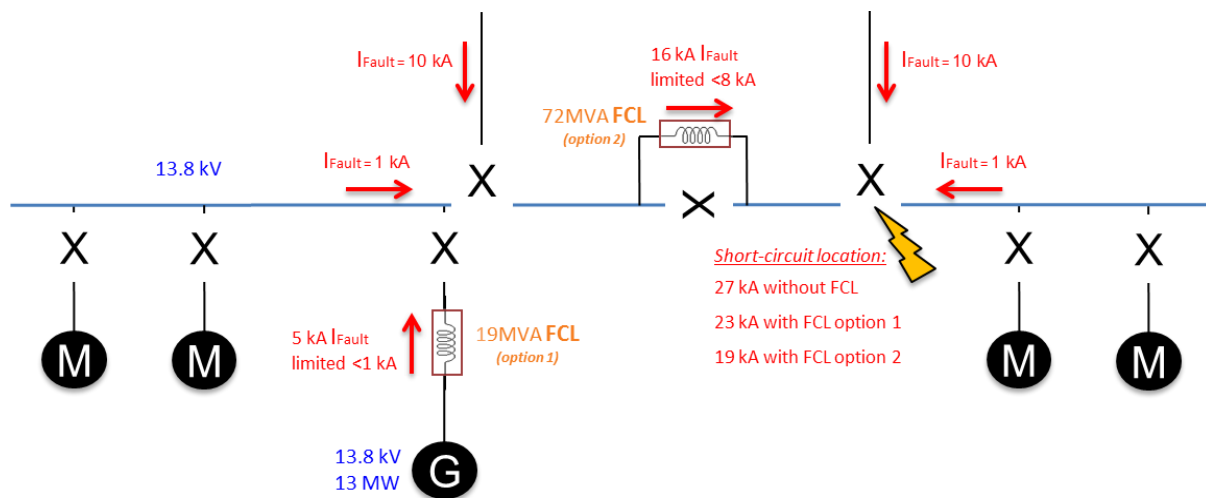

About GridON Ltd

GridON offers fault current limiters for network operators, power producers and industrial customers. By suppressing excessive fault currents, GridON's FCLs enable increased supply by cost-effective network meshing and connection of power generation and renewable energy sources. The FCL improves grid resilience and reliability and significantly lowers capital expenditures and operating costs, while eliminating network upgrades and early retirement of fit-for use equipment.

GridON's FCL is based on combining industry-standard, proven transformer technology with unique and proprietary concept of electro-magnetic flux alteration on a saturated iron core. The fail-safe system responds instantaneously to faults, suppresses fault current for its entire duration, and recovers immediately following fault clearance – being always ready for consecutive fault events.

GridON's commercial FCLs have been operating flawlessly in live networks for nearly 4 years, proving the reliability and maturity of the product. GridON is offering scalable FCL solutions from distribution to very high transmission voltage ratings, in partnership with Wilson Transformer Company - Australia's leading manufacturer of high-quality transformers.

GridON was awarded the Global Cleantech 100 and the UK Energy Innovation in 2013, and received the prestigious ACES Smart Grid and GE ecomagination Powering the Grid awards in 2012.

For further information, please visit www.GridON.com or email sales@GridON.com or call +972.3.711.1183.